



MIDDLE MOUNT

407 / JET RANGER / LONG RANGER

INSTALLATION MANUAL



Tyler - Middle Mount
For *Bell* 407, 206 & 206L Series Helicopters

FAA STC # SH3246NM



PLEASE RETURN THIS MANUAL WITH EQUIPMENT

This manual is available for download from our web site.



Tyler Camera Systems 14218 Aetna Street Van Nuys, California 91401 • USA
www.tylermount.com • **800-390-6070** • (818) 989-4420 • FAX (818) 989-0423





Remove PI-pins or screws from doors and remove doors. Replace PI-pins or screws. Remove all seat and back cushions or other obstacles from seat and floor area.

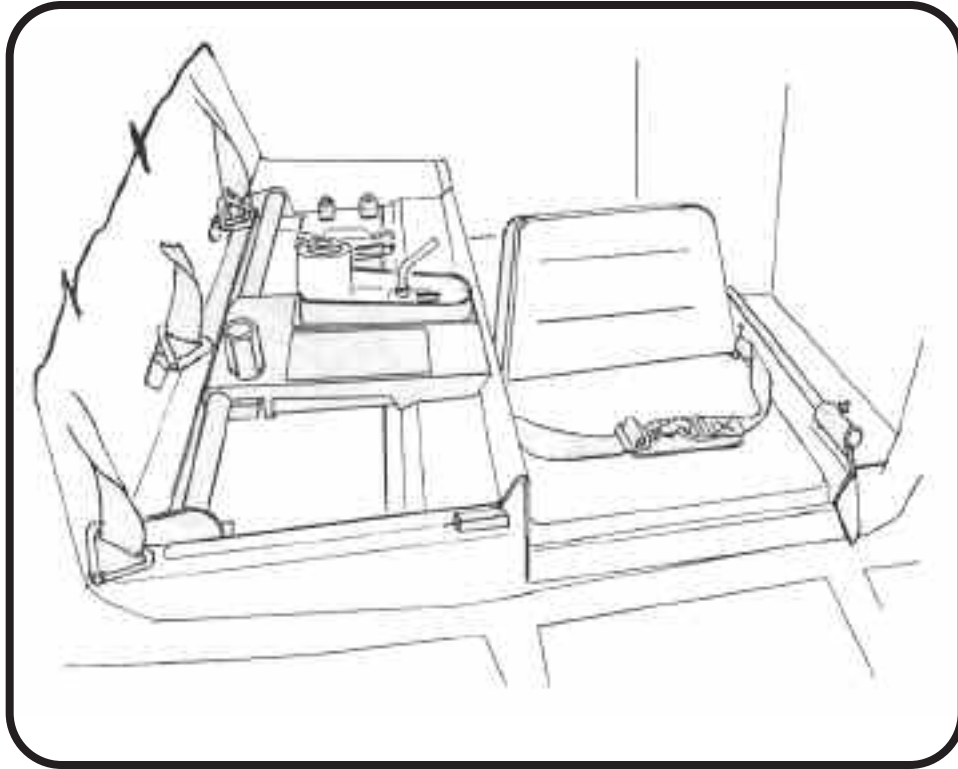

Place the Camera Mount platform on the rear seat of the helicopter (right side) and unfold the camera operator platform.

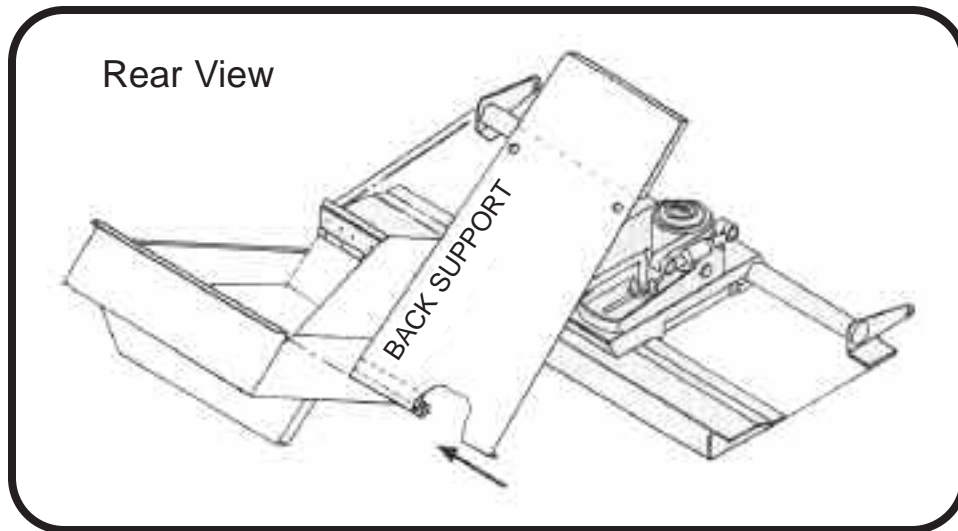

Pivot the seat up @ 45 degrees and slide the back support on from the rear of the operators platform.

Note: The Back Support installs on the right side only.



Hook the two Bungy Cords into the holes in the Back Support. Pull the Bungy Cords over the the pilot's back rest and hook them into the pilot's seat belt "D" Rings (one on each side).

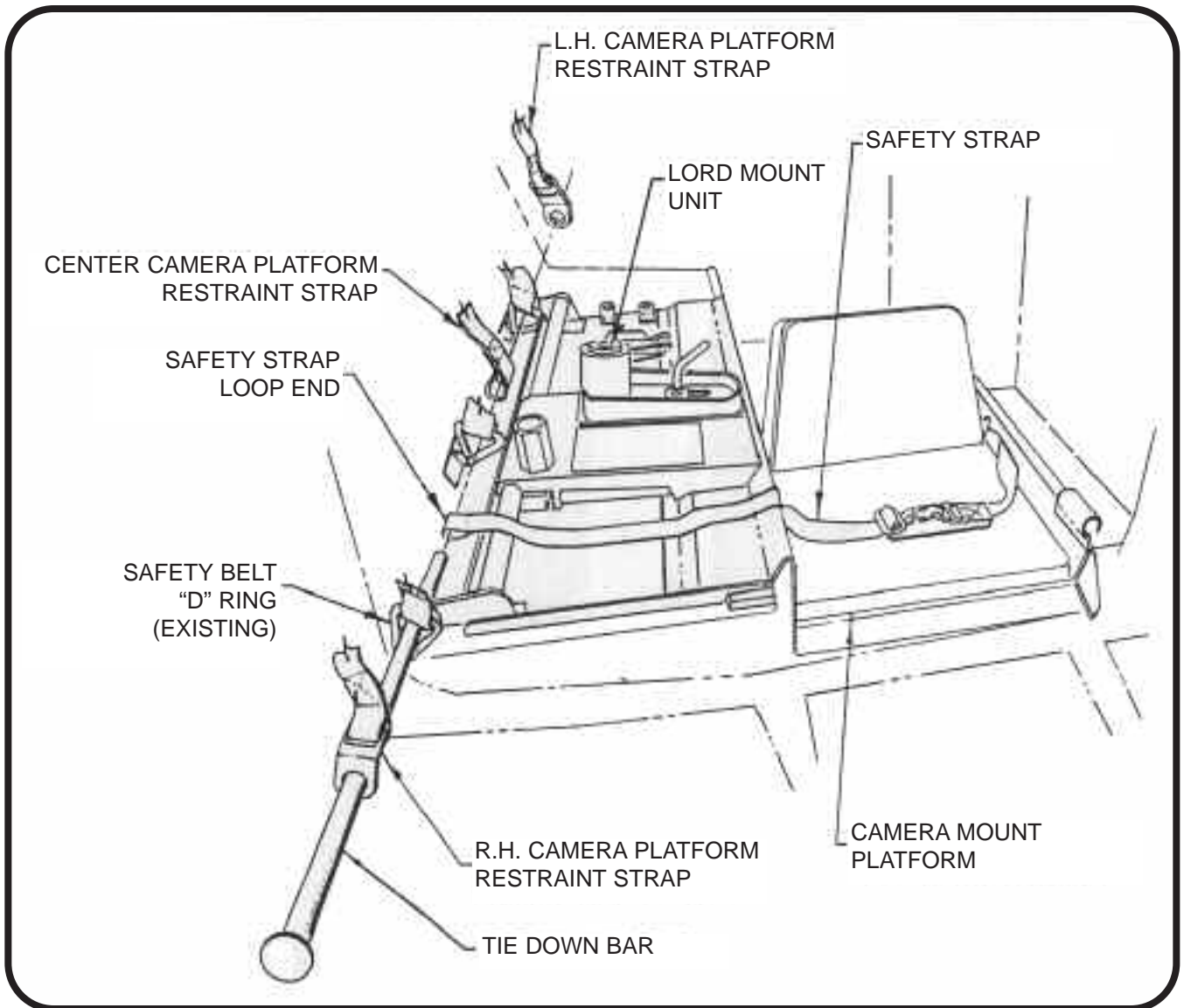

Slip the Tie-down Bar through the (Right Hand) camera mount Restraint Strap, then through the existing helicopter seat belt "D" Ring and through the platform assembly mounting bracket. Continue by sliding the Tie-Down Bar through the camera operator's safety strap and then through the second existing helicopter seat belt "D" Ring, and then through the center camera mount Restraint Strap. Continue sliding the Tie-down Bar through the third and fourth existing helicopter seat belt "D" Rings, and then through the (Left Hand) camera mount Restraint Strap. Secure with a bolt and nut through the end of the Tie-down Bar.

Note: Back Support is not shown.

Camera Platform Safety Strap (right side installation)
Left Side View

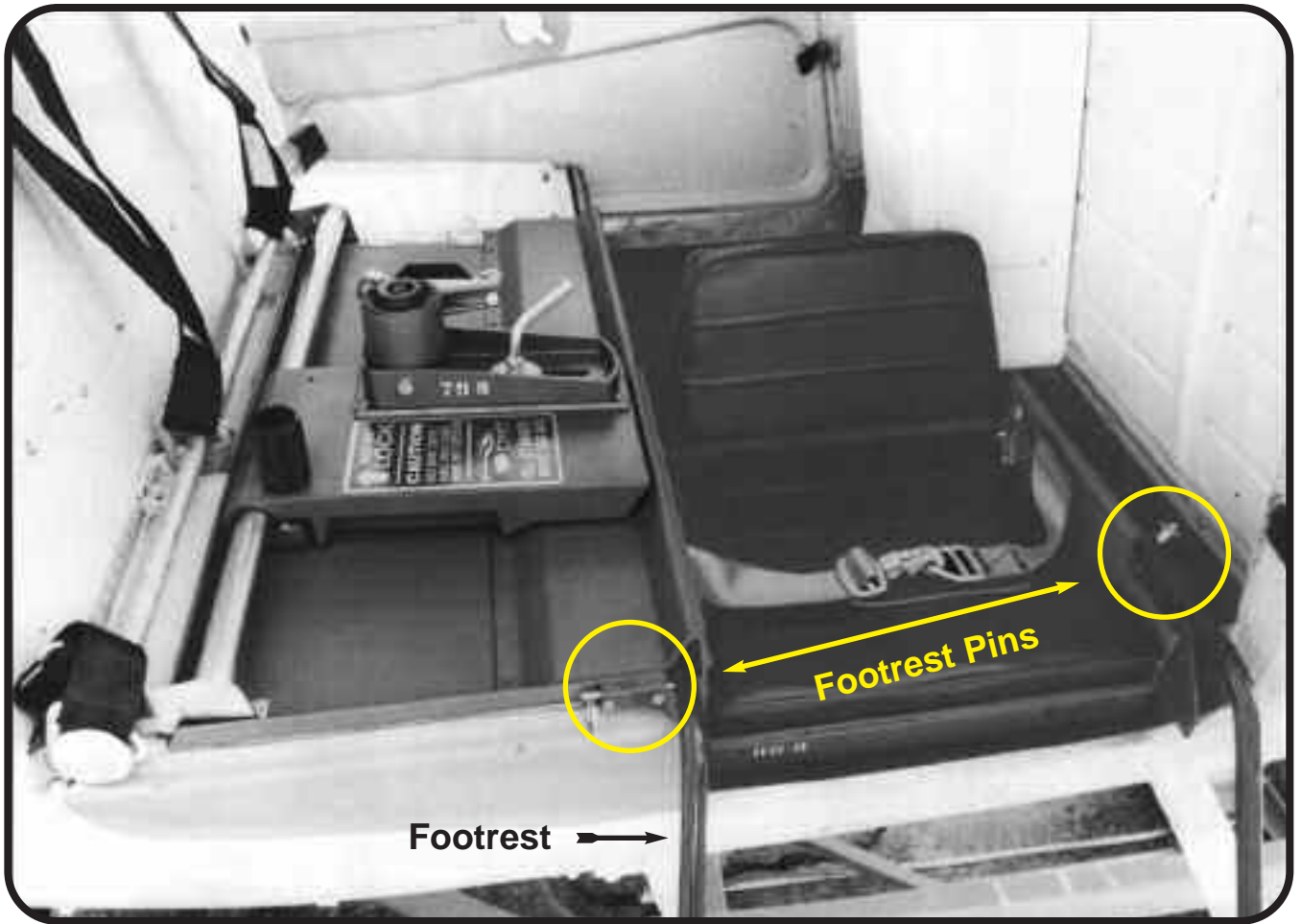

Install the Footrest (optional) Camera Platform and secure with PI-pins.
Note: Back Support is not shown.

Camera Platform Safety Strap (left side installation)
Right Side View

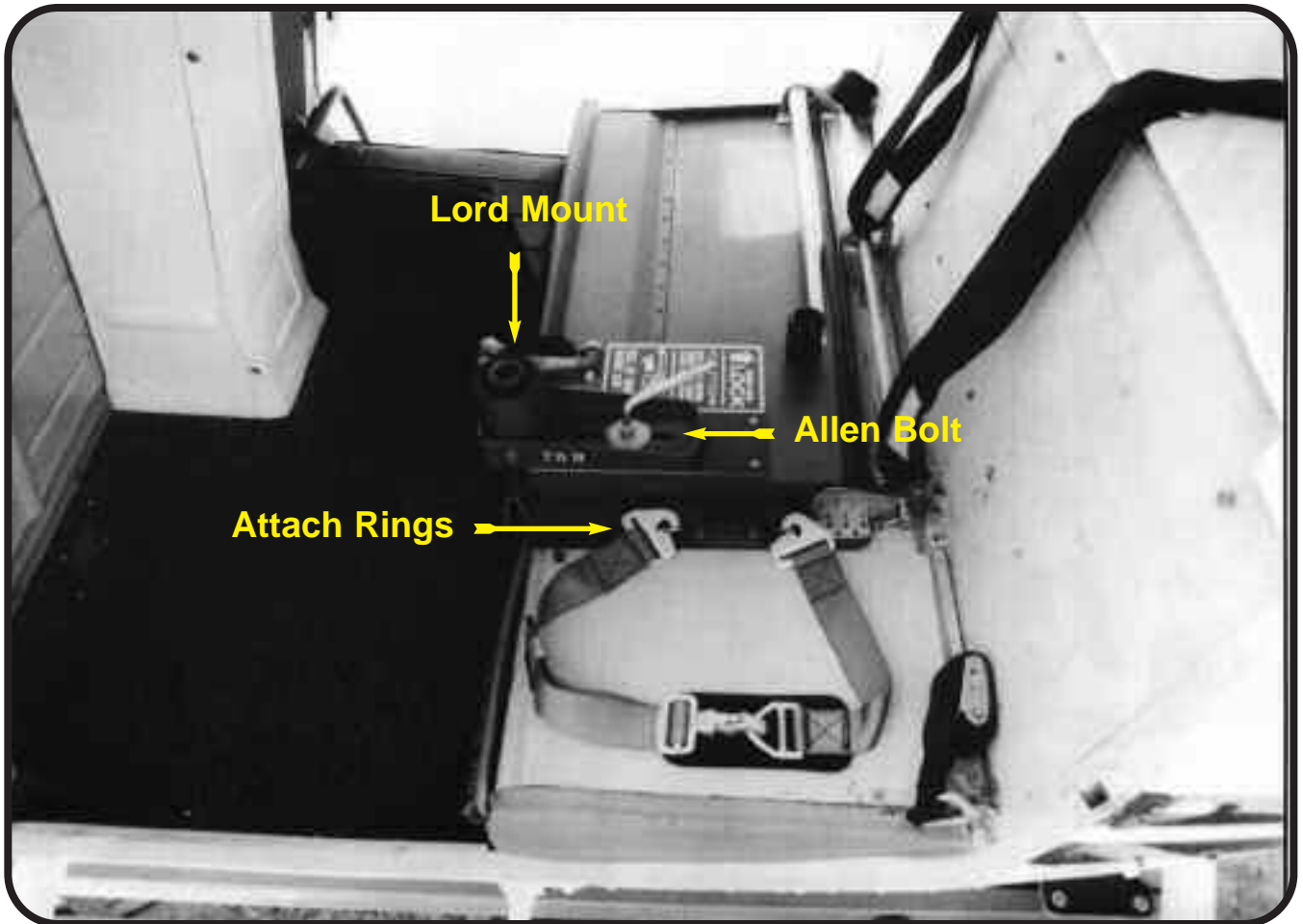

Move mount slider to left side of Camera Platform and secure with lock knob.

Loosen the allen bolt on the tilter and rotate the so the lord mount faces the front of the helicopter, and then tighten the allen bolt.

Remove the camera operator safety strap from the right side seat and clip on to the attach rings on the left side of the Camera Platform as shown.

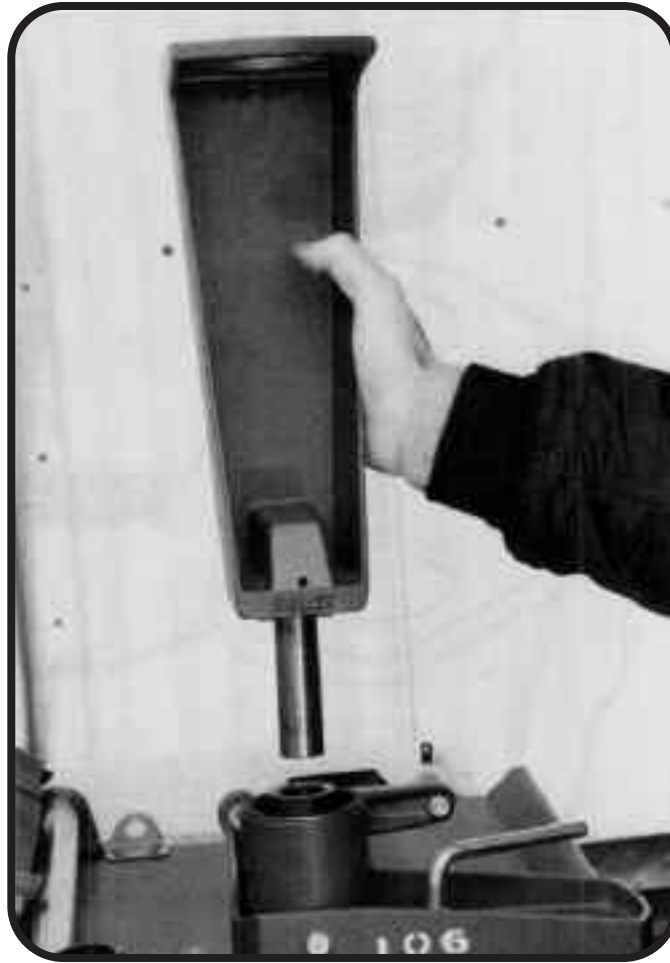

Install the Camera Platform Mast Post into the Lord mount assembly. Rotate until the Mast Post drops into the detent/slot.

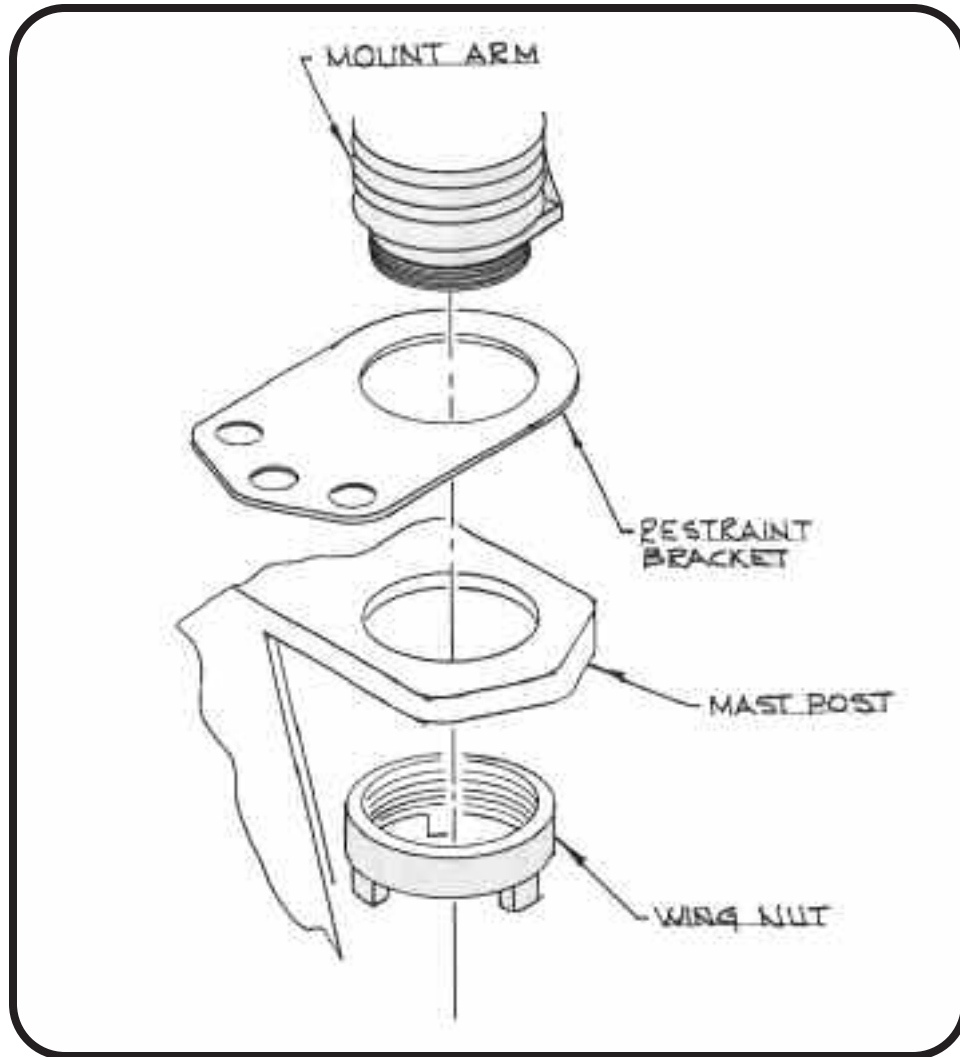

Install the Camera Platform Arm into the Mast Post, with the Restraint Strap Bracket inbetween Mast Post and Arm (facing aft, as shown). Secure with the large Wing Nut. Note: Arm must be held level while tightening Wing Nut. Do not over-tighten Wing Nut. Attach the three Camera Platform Restraint Straps to the holes in the Bracket. Adjust the slack in the Straps to a minimum, but do not snug tight.

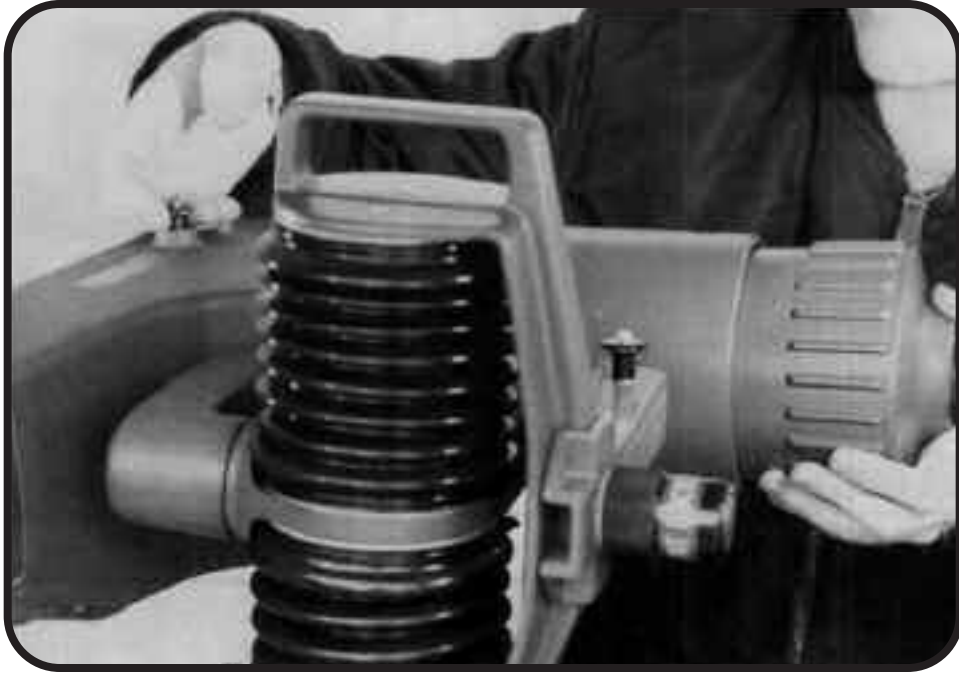

Attach the Balance Weight to the rear of the Camera Platform arm and secure with a PI-pin.

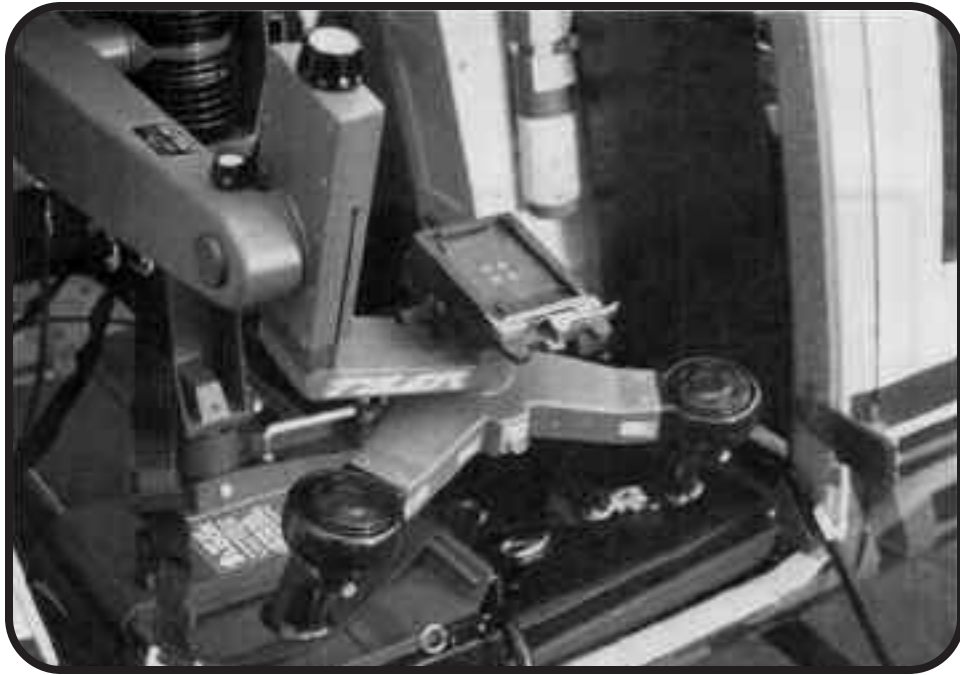

Position the camera package onto the front of the Camera Platform Arm, and close the “receiver” lever and twist the safety knob to the upright position. Plug in the camera and lens cables into the center of the handles.



Install the Lexan Wind-Screen to the existing door hinges. Secure with PI-pins or the bolts and nuts that normally hold the door in place. This completes the Camera Platform installation for Right side filming. Reinstall the Left-Rear helicopter door.

United States Of America
Department of Transportation - Federal Aviation Administration

Supplemental Type Certificate

Number SH3246NM

This Certificate issued to Tyler Camera Systems
14218 Actna Street
Van Nuys, California 91401

certifies that the change in the type design for the following product with the limitations and conditions therefor as specified hereon meets the airworthiness requirements of Part 6 of the Civil Air Regulations. (Certification basis is set forth in Type Certificate Data Sheet H2SW)

Original Product Type Certificate Number : H2SW

Make : Bell Helicopter Textron, Inc.

Model : 206, 206A, 206A-1, 206B, 206B-1, 206L, 206L-1,
206L-3, 206L-4, 407

Description of Type Design Change: Installation of Tyler Middle Mount Camera System in aft compartment of Bell 206 series, and 407 helicopters in accordance with FAA approved Tyler Camera Systems Master Drawing List TCS 5-85, Revision A, dated March 11, 1986, or later FAA approved revision.

Limitations and Conditions: This approval should not be extended to other aircraft of these models on which other previously approved modifications are incorporated unless it is determined that the interrelationship between this change and any of those other previously approved modifications will introduce no adverse effect on the airworthiness of that aircraft. If the holder agrees to permit another person to use this certificate to alter the product, the holder shall give the other person written evidence of that permission. A copy of this STC must be included in the permanent records of each helicopter modified in accordance with this STC.

FAA approved Rotorcraft Flight Manual Supplement, Tyler Camera Systems Document No. TCS 3-85, Revision B, dated January 4, 2005, or later FAA approved revision, is required as part of this installation.

Use of Tyler Installation Manual, Tyler Camera Systems Document No. TCS 3-85, Revision B, dated February 17, 1986, or later dated manual, is required for the installation of this STC.

This certificate and the supporting data which is the basis for approval shall remain in effect until surrendered, suspended, revoked or a termination date is otherwise established by the Administrator of the Federal Aviation Administration.

Date of application: August 24, 1985

Date reissued :

Date of issuance: April 17, 1986

Date amended : May 21, 1986 - May 13, 1994 -
December 9, 1996 - January 11, 2005



By direction of the Administrator

(Signature)

Manager, Airframe Branch
Los Angeles Aircraft Certification Office

(Title)

Any alteration of this certificate is punishable by a fine of not exceeding \$1,000, or imprisonment not exceeding 3 years, or both.



14218 Actina St.
Van Nuys, CA. 91401
Document Number TCS 3-85

**FAA APPROVED
ROTORCRAFT FLIGHT MANUAL
SUPPLEMENT
FOR THE
BELL MODEL 206, 206A, 206A-1, 206B,
206B-1, 206L, 206L-1, 206L-3, 206L-4 & 407
WHEN EQUIPPED WITH THE
TYLER 403 MIDDLE MOUNT**

REGISTRATION #: _____ SERIAL #: _____

This supplement must be attached to the FAA Approved Bell Rotorcraft Flight Manuals. The rotorcraft is modified by the installation of the **Tyler 403 Middle Mount** in accordance with

STC No. SH 3246 NM

The information contained herein supplements or supersedes the basic manual only in those areas listed herein. For limitations, procedures, and performance information not contained in this supplement, consult the basic Rotorcraft Flight Manual.

FAA APPROVED

Patrick Power

Manager, Flight Test Branch, ANM-160L
Federal Aviation Administration
Los Angeles Aircraft Certification Office
Transport Airplane Directorate

FAA Reissue DATE

January 4, 2005

FAA Original Approval Date: 16 April 1986



14218 Astral St.
Van Nuys, CA. 91401
Document Number TCS 3-85

Supplement to the Bell RFM for Models
206, 206A, 206A-1, 206B, 206B-1,
206L, 206L-1, 206L-3, 206L-4 & 407
when modified with the Tyler 403 Middle Mount

STC Number SH 3248 NM

RECORD OF REVISIONS

REV. NO.	PAGES		DESCRIPTION	FAA APPROVED
	NO.	DATE		
Orig.	all	<u>9/14/86</u>	INITIAL RELEASE	<u>[Signature]</u> <small>APPROVED: THESE PARTS MEET THE AIRFRAME CATEGORY, MODEL, CATEGORY AND TYPE REQUIREMENTS LISTED BELOW.</small> <u>9/14/86</u>

4	All	11/26/96	Revision to add Bell Models 326L and 326L4
---	-----	----------	--

FAA approved: [Signature]
Mgt., Flt. Test Br., WTM-150L
FAA, Los Angeles ACO
Transport Airplane Directorate

FAA approval Date: 11-26-96



14218 Astra St.
Van Nuys, CA. 91401
Document Number TCS 3-85

Supplement to the Bell RFM for Models
206, 206A, 206A-1, 206B, 206B-1,
206L, 206L-1, 206L-3, 206L-4 & 407
when modified with the Tyler 403 Middle Mount

STC Number SH 3245 NM

RECORD OF REVISIONS

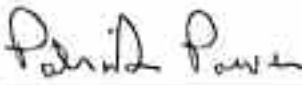
Rev No.	Page No.	Date	Description of Change	FAA Approved
B	Cvr i-ii 1-4	4 Jan 2005	Add B 407 Chg header all pgs. Add ref to 91.105 Add sta loc for wt & bal.	 Mgr. Flight Test Br. ANM-160L, FAA, Los Angeles ACO, Transport Airplane Directorate DATE: <u>January 4, 2005</u>



14218 Aetna St.
Van Nuys, CA, 91401
Document Number TCS 3-85

Supplement to the Bell RFM for Models
206, 206A, 206A-1, 206B, 206B-1,
206L, 206L-1, 206L-3, 206L-4 & 407
when modified with the Tyler 403 Middle Mount

STC Number SH 3246 NM

TABLE OF CONTENTS

SECTION	PAGE
1. GENERAL.....	2
2. LIMITATIONS - Section 1.....	3
3. NORMAL PROCEDURES – Section 2.....	4
4. PERFORMANCE – Section 4.....	4
5. WEIGHT & BALANCE – Section 5.....	4

TABLE OF FIGURES

FIGURE	PAGE
Figure 1 Middle Mount Installed in B 206 Long Ranger.....	2



14218 Aetna St
Van Nuys, CA 91401
Document Number TCS 3-95

Supplement to the Bell RFM for Models
206, 206A, 206A-1, 206B, 206B-1,
206L, 206L-1, 206L-3, 206L-4 & 407
which modified with the Tyler 403 Middle Mount

STC Number SH 3248 NM

1. GENERAL

The Tyler Middle Mount consists of a platform attached in the rear seat area. The primary installation is in the right rear door/seat area, however the platform can be installed in the left rear seat area. The platform is secured to the rear seat area by a set of "D" rings which attach to the seat belt tabs. A single crewmember/operator maneuvers the camera system. A Lexan Wind Guard may be installed at the door attach points. A foot rest attaches to the platform.



Figure 1 Middle Mount Installed in B 206 Long Ranger



14218 Aetna St.
Van Nuys, CA 91401
Document Number TCS 3-85

Supplement to the Bell RFM for Models
206, 206A, 206A-1, 206B, 206B-1,
206L, 206L-1, 206L-3, 206L-4 & 407
when modified with the Tyler 403 Middle Mount

STC Number SH 3246 NM

The basic Tyler Camera Systems 403 Middle Mount/Platform configuration is with Camera Assembly (Camera, Mount, gyros and film magazine) installed. Operation, installation and removal of the Camera Assembly and Camera Ballast are to be conducted in accordance with Tyler Camera Systems Installation Manual No. TCS 3-85.

The platform may be installed or removed by a Tyler Camera Systems trained technician, pilot, or mechanic, and must be recorded in accordance with FAR 43.9

2. LIMITATIONS - Section 1

- The camera operator, performing an essential function in conjunction with the operation, is considered to be a required crewmember in accordance with the provisions of FAR 91.105 B (1) (2) while using the Middle Mount/Platform Camera System.
- V_{NE} = 100 MPH or 87 KCAS power ON or OFF with platform, with or without camera assembly and Lexan Wind Guard, with ONE or BOTH AFT cabin doors off, sea level to 3000 ft density altitude.
- Decrease V_{NE} 2.3 MPH or 2 KCAS per 1000 ft. above 3000 ft. density altitude.
- Protracted Rearward and Sideward flight prohibited with any combination of doors OFF, with or without camera assembly and Lexan Wind Guard.



14218 Aetna St.
Van Nuys, CA 91401
Document Number TCS 3-85

Supplement to the Bell RFM for Models
206, 206A, 206A-1, 206B, 206B-1,
206L, 206L-1, 206L-3, 206L-4 & 407
when modified with the Tyler 403 Middle Mount

STC Number SH 3246 NM

- Completed Tyler Middle Mount, may use ships auxiliary power outlet, but may not exceed 28 volts, 400 watts.

3. NORMAL PROCEDURES – Section 2

- Check the installation for security.
- Secure all loose items in the cabin area.

4. PERFORMANCE – Section 4

- No change to hover performance
- Use the published doors OFF climb performance

5. WEIGHT & BALANCE – Section 5

- Seat position for the 206 A & B for the right side configuration
 - Longitudinal Sta = 83
 - Lateral Sta = +17
- Seat position for the B 206 L, L-1, L-3 & 407 for the right side configuration
 - Longitudinal Sta = 101
 - Lateral Sta = + 17

MAJOR REPAIR AND ALTERATION
(Airframe, Powerplant, Propeller, or Appliance)

FOR FAA USE ONLY

OFFICE IDENTIFICATION

INSTRUCTIONS: Print or type all entries. See FAR 43.9, FAR 43 Appendix B, and AC 43.9-1 (or subsequent revision thereof) for instructions and disposition of this form.

1. AIRCRAFT	MAKE Bell	MODEL 206 B-III
	SERIAL NO. 1234	NATIONALITY AND REGISTRATION MARK N5678M
2. OWNER	NAME (As shown on registration certificate) Local Copters Inc.	ADDRESS (As shown on registration certificate) Your Town, USA

3. FOR FAA USE ONLY

**FAA FORM 337
TYLER MIDDLE MOUNT
SAMPLE ONLY**

4. UNIT IDENTIFICATION

5. TYPE

UNIT	MAKE	MODEL	SERIAL NO.	5. TYPE	
				REPAIR	ALTERATION
AIRFRAME	***** (As described in item 1 above)*****				X
POWERPLANT					
PROPELLER					
APPLIANCE	TYPE				
	MANUFACTURER				

6. CONFORMITY STATEMENT

A. AGENCY'S NAME AND ADDRESS	B. KIND OF AGENCY	C. CERTIFICATE NO.
Local Copters Inc. Your Town, USA	<input checked="" type="checkbox"/> U.S. CERTIFICATED MECHANIC	CRS 000-000
	<input type="checkbox"/> FOREIGN CERTIFICATED MECHANIC	
	<input type="checkbox"/> CERTIFICATED REPAIR STATION	
	<input type="checkbox"/> MANUFACTURER	

D. I certify that the repair and/or alteration made to the unit(s) identified in item 4 above and described on the reverse or attachments hereto have been made in accordance with the requirements of Part 43 of the U.S. Federal Aviation Regulations and that the information furnished herein is true and correct to the best of my knowledge.

DATE 1-1-86	SIGNATURE OF AUTHORIZED INDIVIDUAL <i>John Doe</i>
----------------	---

7. APPROVAL FOR RETURN TO SERVICE

Pursuant to the authority given persons specified below, the unit identified in item 4 was inspected in the manner prescribed by the Administrator of the Federal Aviation Administration and is APPROVED REJECTED

BY	FAA FLT. STANDARDS INSPECTOR	MANUFACTURER	INSPECTION AUTHORIZATION	OTHER (Specify)
	FAA DESIGNEE	XX REPAIR STATION	CANADIAN DEPARTMENT OF TRANSPORT INSPECTOR OF AIRCRAFT	
DATE OF APPROVAL OR REJECTION 1-1-86	CERTIFICATE OR DESIGNATION NO. CRS 000-000	SIGNATURE OF AUTHORIZED INDIVIDUAL		

NOTICE

Weight and balance or operating limitation changes shall be entered in the appropriate aircraft record. An alteration must be compatible with all previous alterations to assure continued conformity with the applicable airworthiness requirements.

8. DESCRIPTION OF WORK ACCOMPLISHED (if more space is required, attach additional sheets. Identify with aircraft nationality and registration mark and date work completed.)

Installation of Tyler Camera Systems Camera Mount.

Installation of Tyler Middle Mount Model 403 and Camera System in accordance with STC SH3246NM dated April 17, 1986 using Tyler Installation Manual Model 403.

Limitations are stated in Flight Manual Supplement TCS 15-85.

Weight and balance revised to reflect camera and mount installation.

XXXXXXXXXXXXXXXXXXXXX NOTHING FOLLOWS XXXXXXXXXXXXXXXXXXXXX

**FAA FORM 337
TYLER MIDDLE MOUNT
SAMPLE ONLY**

SAMPLE ONLY

SAMPLE ONLY

BELL HELICOPTER WEIGHT AND BALANCE

MODELS 206A, 206B & BIII

<u>ITEM</u>	<u>WEIGHT</u>	<u>ARM</u>	<u>MOMENT</u>
Middle Mount	149.0	99.0	14,751.0
Camera & Film Magazine	32.0	99.0	3,168.0

TOTAL	181.0	99.0	17,919.0

Major Mount	180.0	99.0	17,820.0
Camera & Film Magazine	42.0	99.0	4,158.0

TOTAL	222.0	99.0	21,978.0

NOTE: LATERAL C.G. NOT NORMALLY AFFECTED BY THIS INSTALLATION.

BELL HELICOPTER WEIGHT AND BALANCE

MODELS 206, 206 L, 407

<u>ITEM</u>	<u>WEIGHT</u>	<u>ARM</u>	<u>MOMENT</u>
Middle Mount	149.0	117.0	17,433.0
Camera & Film Magazine	32.0	117.0	3,744.0

TOTAL	181.0	117.0	21,177.0

Major Mount	180.0	117.0	21,060.0
Camera & Film Magazine	42.0	117.0	4,914.0

TOTAL	222.0	117.0	25,974.0

NOTE: LATERAL C.G. NOT NORMALLY AFFECTED BY THIS INSTALLATION.