

50K

SoftSun®





Linear Daylight Source

In response to the demand for larger sources of light for both location and studio production, Lightning Strikes, Inc. developed our SoftSun product line. A daylight 5400° Kelvin lighting system, SoftSun units are the largest single bulb light sources commercially available worldwide.



FEATURES INCLUDE:

 **Instant start** – SoftSun requires NO warm-up time. Maximum power and proper color temperature are achieved the moment it is struck. Hot restrike is possible within one minute.

 **Fully dimmable** – SoftSun is the ONLY daylight color temperature light source that can be dimmed through 97% of its range with minimal shift in color temperature while remaining **flicker-free**. at any shutter angle or frame rate to 400 fps. Dimming can be remotely controlled via DMX or the SoftSun digital control unit.

 **ESL™ Lamp Technology** – SoftSun color spectrum is smooth and even with none of the undesirable color spikes or gaps associated with HMI or Tungsten lamps. Color stays true regardless of lamp age.

 **Naturally soft source** – SoftSun's unique large linear bulb and reflector design produces a light source that begins as a soft, natural light without the need for additional diffusion.

ONE SOURCE = ONE SHADOW

50K SoftSun™ Linear Daylight Source

Technical Specifications

Head

Wattage: 50,000
 Lamp Type: ESL™ (Enhanced Spectrum Long Arc)
 Lamp Mount: Shock Isolated
 Color Temp: 5400 K
 CRI: 96
 Dimensions: 84" w 41" h 22" d
 Weight: 220-lbs.
 Shipping Weight: 700-lbs
 Mounting: 3 Junior Pins

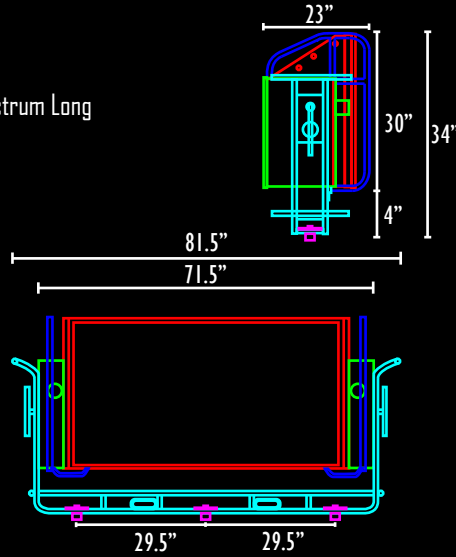

Power Supply

Input Power 50/60Hz: 380/480V AC Three Phase
 Power Consumption: 265 amps
 Dimensions: 27" w 42" h 33" d
 Weight: 440-lbs.
 Shipping Weight: 500-lbs.

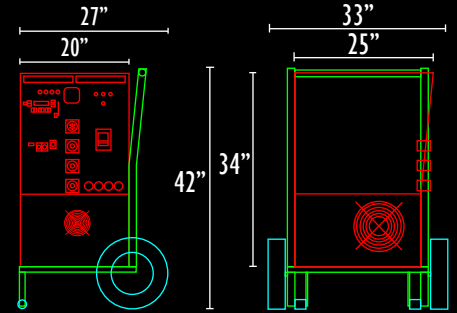

Photometrics

ftc	spot	4,000	1,140	530	303	133	85	12	3
	flood	1,840	545	251	143	63	35	5.7	1.4
feet		25	50	75	100	150	200	500	1,000
	meters	7.6	15.2	22.9	30.5	45.7	61	152.4	304.8
lux	spot	43,055	12,271	5,705	3,261	1,432	915	129	32
	flood	19,806	5,866	2,702	1,539	678	377	61	15

Beam Spread

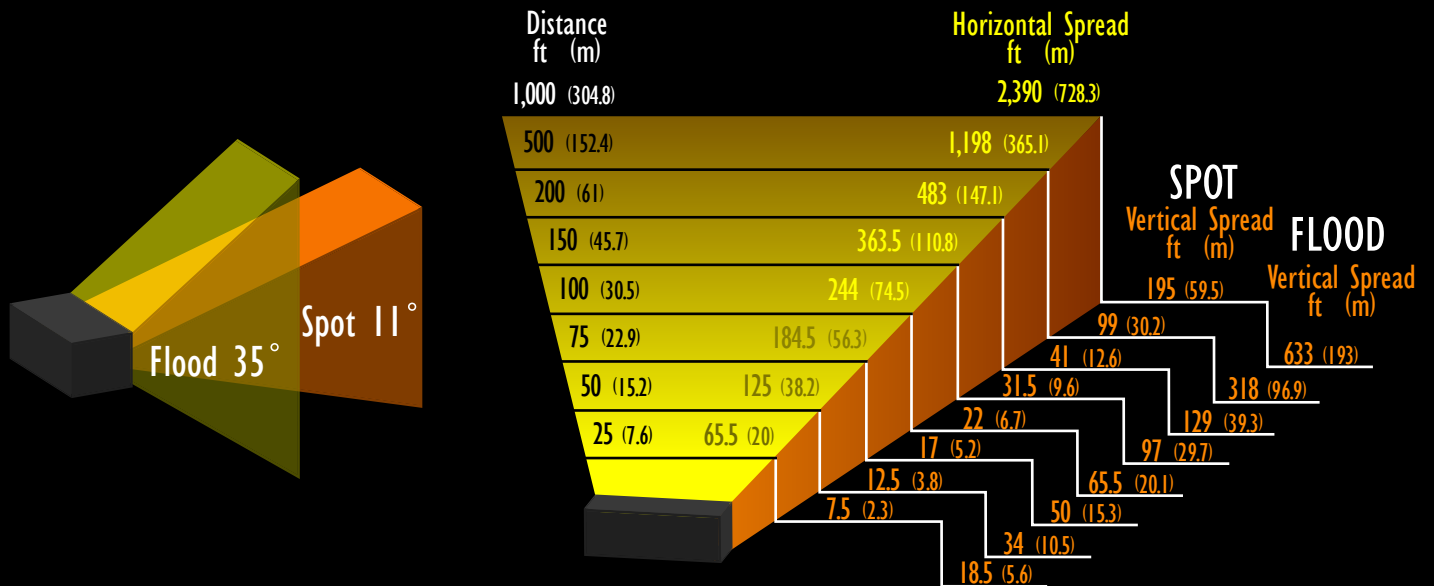

W W W . L I G H T N I N

50K SoftSun™ vs. 18K HMI

To fill the need for a large, dimmable, daylight source of light, Lightning Strikes, Inc. developed our SoftSun product line. The 50K SoftSun's wide beam contributes to a tremendous spread from a single light source. In a quantitative comparison of published data for the 50K SoftSun and the leading 18K HMI*, telling differences emerge in the areas of beam spread, resources and overall value.

*18K ArriMAX™

Beam Spread Comparison

Beam Angle

In this top view, with a beam angle of 50° at 100ft, (30.5 m) the horizontal spread of the ArriMAX™ is 91.9 feet (28 m). With a beam angle of 100° at the same distance, the horizontal spread of a 50K SoftSun is 244 feet (74.5 m).

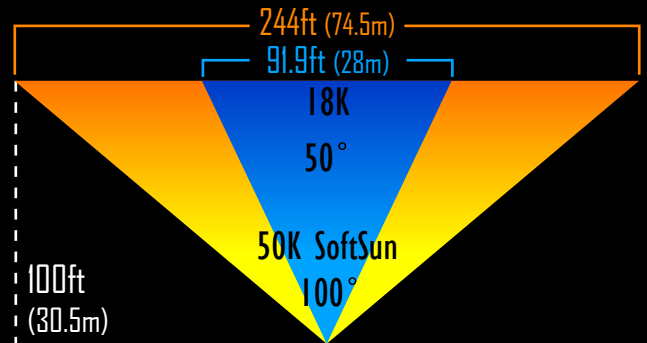

Beam Area

To cover the same area as a 50K SoftSun, about three ArriMAX™ units are needed at a distance of 100 feet (30.5m).

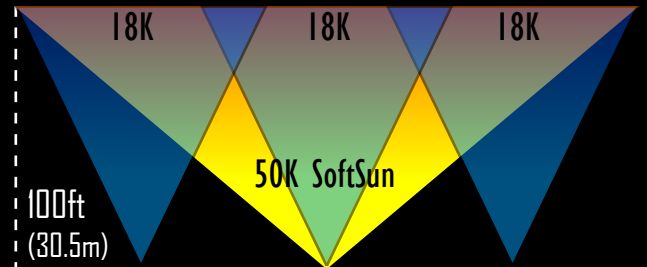

Beam Intensity

To then achieve a uniform intensity equal to a 50K SoftSun set at full flood at a distance of 100ft (143 footcandles/1,539 lux), a total of five ArriMAX™ units are needed (1 ArriMAX™ = 138.9 footcandles/1,495 lux at 100ft/30.5m), taking into consideration the 50% falloff from the center beam. It should be noted that additional diffusion on the 18Ks will be necessary to match the soft light of the SoftSun, resulting in some loss of light from the 18K ArriMAX™ units.

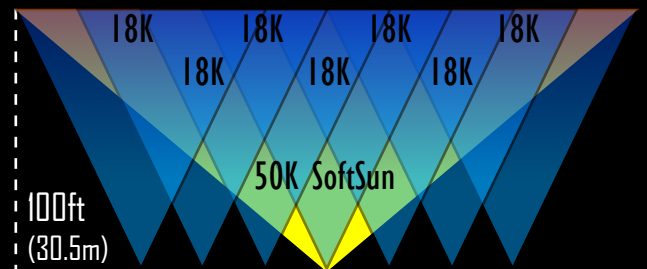

Value Comparison

Rigging five 18Ks requires five electricians to lay power, properly align each fixture, mount and support all related grip equipment. If mounted on cranes, additional labor is necessary to man the equipment in the basket.

A 50K SoftSun requires three electricians to run power and mount the fixture. If mounted on a crane, no additional labor is needed in the basket due to SoftSun's remote focus and dimmability.

Estimated Value Comparison

Unit(s)	18K = 5	50K SoftSun = 1
Electricians/Labor	5+	3
Cable Run(s)	5	1
Diffusion	20' x 20' silk, frame, etc.	Optional
Support	5 stands or 3 cranes	2 stands or 1 crane

The 50K SoftSun is the only daylight source that offers the ability to dim from 50K down to 1.5K, with a change of less than 100° K throughout.